



## Electronic Service Manuals

This electronic document is provided as a service to our customers. We do not create the contents of the information contained in this document. Should you have detailed questions pertaining to the information contained in this document, you may contact Michco, or the manufacturer which provided the original information in this electronic deliverable. Michco's only part in this electronic deliverable was the electronic assembly process. By providing this manual on line we are not guaranteeing parts availability.

You may contact Michco through the following methods:

Phone (517) 484-9312 or (800) 331-3339

2011 N. High St. -- Lansing, Michigan -- 48906

Fax: (517) 484-9836

Email: [CustServe@Michco.com](mailto:CustServe@Michco.com)

Web site: [www.Michco.Com](http://www.Michco.Com)

Parts Web site: [www.FloorMachineParts.Com](http://www.FloorMachineParts.Com)

Order Parts on Line at:

**[www.FloorMachineParts.Com](http://www.FloorMachineParts.Com)**

Directly to Parts & Service:

By Email: **[Shop@Michco.com](mailto:Shop@Michco.com)**

By Fax: (517) 702-2041

By Voice: Use numbers above.

**Serving the Cleaning Industry Since 1922**

Notice: All copyrighted material remains property of original owners, all trademarks are property of respective owners. Manuals are subject to Manufacturer's reproduction limitations. Originals or reproductions were provided by manufacturers through a request. We make no warranty as to the correctness of information provided in this document and you assume all risk. By placing these manuals on line we are not declaring our corporation to be an manufacturer authorized dealer or provider, please check our web site for authorized manufacturers we represent.

  
**Parker**®

# Estate Master

MA-475-D Estate  
Master Hitch

**EM83100**

■ OPERATION ■ SERVICE ■ PARTS ■ CARE

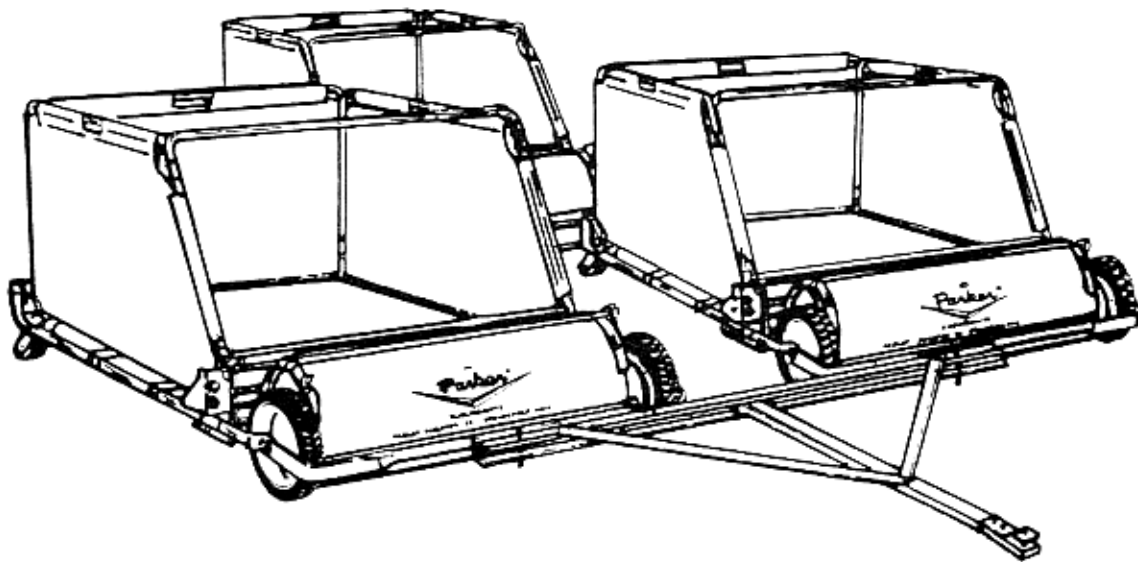

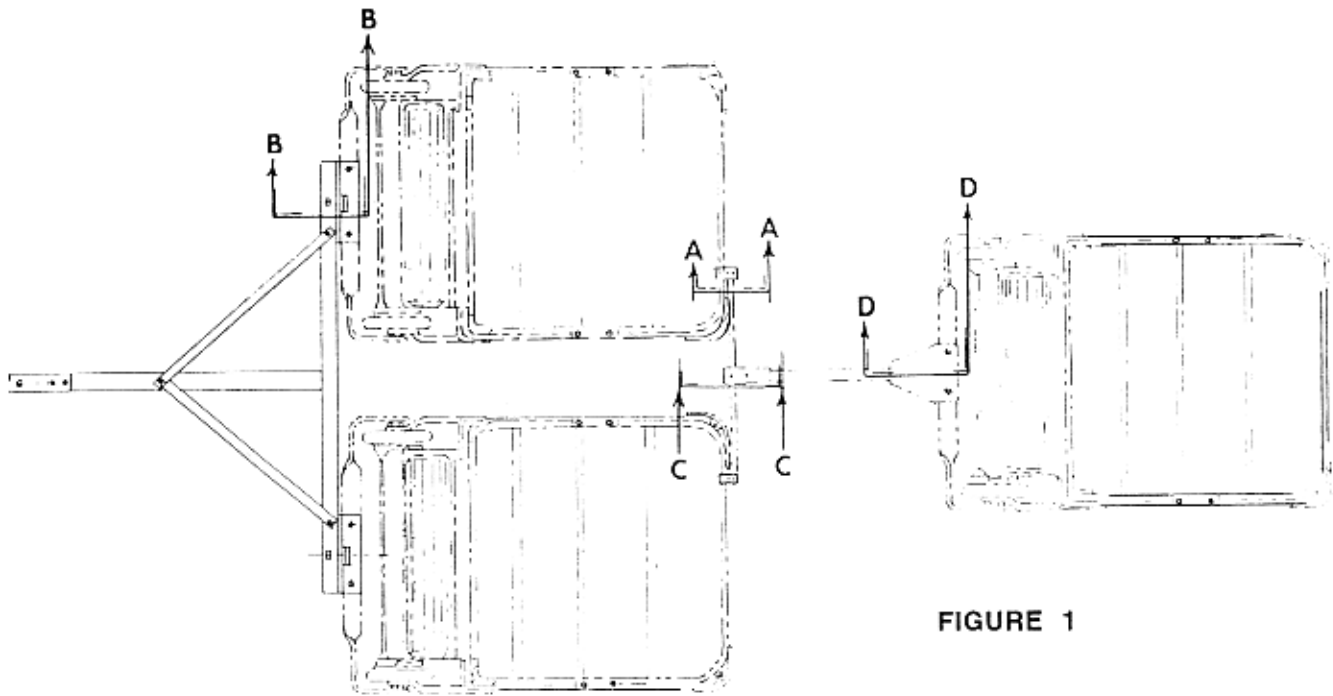
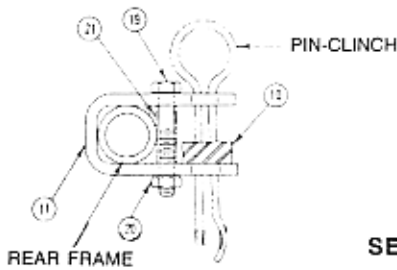
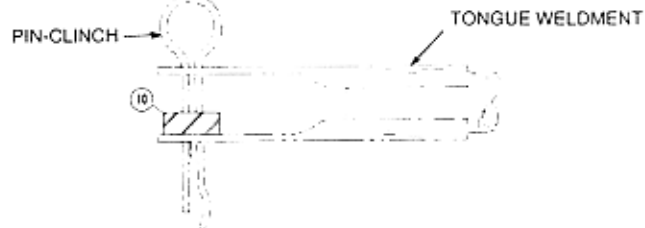

FIGURE 1

SECTION A-A



SECTION C-C



SECTION B-B

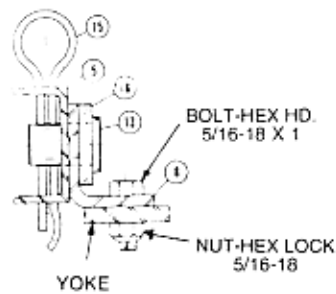

SECTION D-D

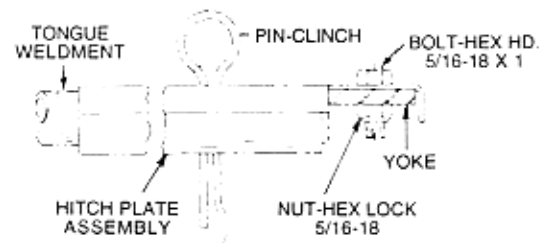

**ALWAYS GIVE THE FOLLOWING INFORMATION WHEN ORDERING REPAIR PARTS:**

- |                               |                        |
|-------------------------------|------------------------|
| 1. PART NUMBER (not ref. no.) | 3. DESCRIPTION OF PART |
| 2. QUANTITY NEEDED            | 4. MODEL NO. EM83100   |

If unable to obtain parts locally, write down above information and send to:  
 PARKER SWEEPER CO., 111 SOUTH ROHLWING ROAD, ADDISON, ILLINOIS 60101.

Your unit is right hand (R.H.) or left hand (L.H.) as you stand behind it.

# ASSEMBLY INSTRUCTIONS AND PARTS LIST

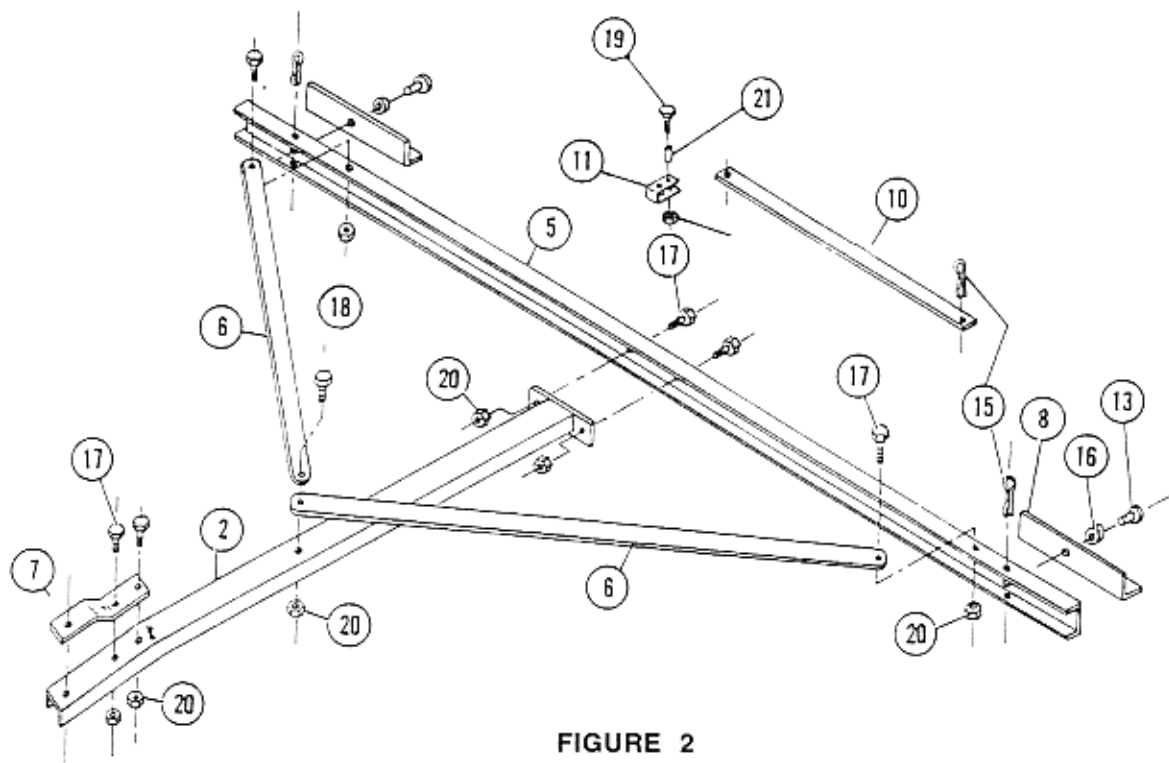

FIGURE 2

## PARTS LIST

Item	Part No.	Qty.	Description	Item	Part No.	Qty.	Description
2	76-51-B	1	Tongue Weldment	15	81-14-A	4	Pin Clinch
5	68-73-C	1	Draw Bar	16	64-134-A	2	Spacer
6	76-50-B	2	Brace	17	713027	6	Bolt, Hex Hd. 5/16-18 x 1
7	58-107-B	1	Bracket	18	713028	1	Bolt, Hex Hd. 5/16-18 x 1 1/4
8	76-48-C	2	Bracket	19	713031	2	Bolt, Hex Hd. 5/16-18 x 2
10	82-46-A	1	Link	20	711374	9	Nut, Hex Hd. Lock 5/16-18
11	82-42-B	2	Bracket	21	80-238-A	2	Insert
13	68-71-A	2	Pin Swivel				

## ASSEMBLY INSTRUCTIONS

Ref. Fig. 2: Using the bolts and nuts shown, attach bracket (item 7) to the tongue weldment (item 2).

Attach the tongue weldment (item 2) to the draw bar (item 5).

Ref. Fig. 1, Section B-B: Attach the hitch assembly to the sweeper yokes using the bolts and nuts from the sweeper's single tongue weldment (hitch).

Ref. Fig. 1, Section C-C: Attach the single tongue weldment (hitch) to the link bar (item 10) using clinch pin.

Section D-D shows single tongue weldment attached to the link bar (item 10).

## LIMITED WARRANTY

The Parker Sweeper Company warrants to the original purchaser/user that this product is free from defects in workmanship and materials under normal use and service for a period of two years from date of purchase. In addition, Parker Sweeper Company, will, at its option, honor labor warranty claims for the first 12 months from date of sale, provided such claims are submitted through and approved by factory authorized repair stations. Parker Sweeper Company, will, at its option, repair or replace without charge, except for transportation costs, parts that fail under normal use and service when operated and maintained in accordance with the applicable operation and instruction manuals.

This warranty does not apply to normal wear, or to items whose life is dependent on their use and care, such as belts, cords, switches, hoses, rubber parts, electrical motor components or adjustments. Parts not manufactured by Parker Sweeper Company such as engines, batteries, battery chargers, hydraulic pumps, and tires are covered by and subject to the warranties and/or guarantees of their manufacturers. Please contact Parker Sweeper Company for procedures in warranty claims against these manufacturers.

**Special warning to purchaser** -- Use of replacement filters and/or pre-filters not manufactured by Parker Sweeper Company or its designated licensees, will void all warranties expressed or implied.

A potential health hazard exists without exact original equipment replacement.

All warranted items become the sole property of Parker Sweeper Company or its original manufacturer, whichever the case may be.

Parker Sweeper Company disclaims any implied warranty, including the warranty of merchantability and the warranty of fitness for a particular purpose. Parker Sweeper Company assumes no responsibility for any special, incidental or consequential damages.

This limited warranty is applicable only in the U.S.A. and Canada, and is extended only to the original user/purchaser of this product. Customers outside the U.S.A. and Canada should contact their local distributor for export warranty policies. Parker Sweeper Company is not responsible for costs or repairs performed by persons other than those specifically authorized by Parker Sweeper Company. This warranty does not apply to damage from transportation, alterations by unauthorized persons, misuse or abuse of the equipment, use of non-compatible chemicals, or damage to property, or loss of income due to malfunctions of the product.

If a difficulty develops with this machine, you should contact the dealer from whom it was purchased.

This warranty gives you specific legal rights, and you may have other rights which vary from state to state. Some states do not allow the exclusion or limitation of special, incidental or consequential damages, or limitations on how long an implied warranty lasts, so the above exclusions and limitations may not apply to you.



**Parker Sweeper Company**  
*A Division of Minuteman International, Inc.*

111 South Rohwing Road  
Addison, Illinois 60101  
Phone: (708) 627-6900  
Fax: (708) 627-1130